

# Articles

Contribution from the Lawrence Berkeley Laboratory and Department of Chemistry, University of California, Berkeley, California 94720, and Department of Chemistry, University of the Pacific, Stockton, California 95211

## Chemistry of a High-Oxidation-Level Manganese Porphyrin in Aqueous Solution

L. O. Spreer,\* Anthony Leone, A. C. Maliyackel, J. W. Otvos, and Melvin Calvin

Received April 14, 1987

Manganese(III) tetrakis(*N*-methyl-4-pyridiniumyl)porphyrin ( $\text{Mn}^{\text{III}}\text{P}^+$ ) (chloride salt) and other water-soluble manganese(III) porphyrins undergo facile one-electron electrochemical or chemical oxidation in alkaline solution. Best available evidence indicates that the final oxidized species is a manganese(IV)  $\mu$ -oxo dimer,  $\text{PMn}^{\text{IV}}\text{-O-Mn}^{\text{IV}}\text{P}^{2+}$ . This same species is also produced by the reaction of manganese(II) porphyrin and oxygen. The Mn(IV)  $\mu$ -oxo dimer has limited stability in water returning to 90–94% of the original Mn(III) porphyrin. The rate of this reaction is pH dependent with faster rates at lower pH. Oxygen is not produced during this reduction process. Rather, the reaction involves an unusual disproportionation in which a small percentage of the porphyrin macrocycles supply multiple electrons to reduce the remainder of the oxidized dimer. It was also found that the manganese(IV) dimer reacts rapidly with water-soluble olefins as it also does in aprotic solvents. A mechanism for the disproportionation reaction is discussed with a rate-determining step involving rearrangement of charge within the symmetric dimer to one with both oxidation equivalents on one metalloporphyrin unit, viz.,  $\text{PMn}^{\text{IV}}\text{-O-Mn}^{\text{III}}\text{P}^+$  or  $\text{PMn}^{\text{III}}\text{-O-Mn}^{\text{IV}}\text{P}^{2+}$ . This species undergoes nucleophilic attack by water or hydroxide, producing an isoporphyrin or bilirubin type molecule that has many olefinic bonds capable of reaction with remaining Mn(IV)  $\mu$ -oxo dimer. Since coordination by  $\text{OH}^-$  to the manganese center favors the higher manganese(IV) oxidation level, the pH dependence of the disproportionation can be explained by rearrangement within the dimer to a porphyrin-centered oxidation site.

### Introduction

A number of efficient multiple-electron redox catalysts are found in natural systems. The development of homogeneous multiple-electron catalysts has proven very difficult in the laboratory. Our interest in artificial photosynthetic systems led us to consider manganese porphyrin compounds as potential oxidation catalysts to mediate the four-electron conversion of water to oxygen.<sup>1,2</sup> It has long been known that water-soluble manganese porphyrins that have been oxidized above the manganese(III) porphyrin level are unstable. These high-valent manganese porphyrins revert to the original Mn(III) species,<sup>3</sup> and speculation has focused on water as the reducing agent in this reaction with oxygen proposed as the product.<sup>4</sup>

We recently described a system<sup>5</sup> for the photooxidation of manganese(III) tetrakis(*N*-methyl-4-pyridiniumyl)porphyrin,  $\text{Mn}^{\text{III}}\text{P}^+$ .<sup>6</sup> The photooxidized product is reduced to the original  $\text{Mn}^{\text{III}}\text{P}^+$  in the dark, and the oxidation–reduction sequence could be cycled repeatedly. Thus, this system appeared to satisfy many critical requirements of an artificial photosynthesis assembly.

This paper reports work aimed at characterizing the oxidized form of the manganese porphyrin and also examines the nature of the reduction reaction. We find that the best available evidence supports formulation of the oxidized species as a Mn(IV)  $\mu$ -oxo dimer,  $\text{PMn}^{\text{IV}}\text{-O-Mn}^{\text{IV}}\text{P}^{2+}$ . Careful search showed oxygen was not a product of the reduction reaction. We have found that the instability of the  $\text{PMn}^{\text{IV}}\text{-O-Mn}^{\text{IV}}\text{P}^{2+}$  species is due to a highly unusual disproportionation reaction in which a small (4–8) percentage of the porphyrin macrocycles supply multiple electrons (10–16 electrons each) to reduce the remainder of the oxidized Mn species. Water-soluble manganese porphyrins, therefore, are not good candidates for relays in water-splitting systems. However, we have also found that the high-valent manganese porphyrin species reacts rapidly with water-soluble olefins, presumably to form olefin oxidation products, possibly epoxides.<sup>7</sup> Manganese porphyrin species can, therefore, be used to catalyze unusual photochemical hydrocarbon oxidation reactions.

### Experimental Section

Manganese(III) tetrakis(*N*-methyl-4-pyridiniumyl)porphyrin ( $\text{Mn}^{\text{III}}\text{P}^+$ ) (chloride salt) was prepared by literature methods<sup>8</sup> or pur-

chased from Midcentury Chemical Co. and further purified by chromatography. Purity was checked by elemental analysis and visible spectrum. All other materials were of the highest available purity and were used as received. Deionized water was passed through a Millipore Milli-Q system. This water was then either used immediately or doubly distilled through an all-glass still before immediate use. Argon gas was deoxygenated by passage over BASF catalyst maintained at 150 °C and then through a Nanochem Purification System (Semi Gas Systems, Inc.).

Electronic absorption spectra were taken on a Hewlett-Packard 8450A UV/visible spectrophotometer. Magnetic moments in solution were determined by the Evans method<sup>9</sup> using a 200-MHz Fourier transform <sup>1</sup>H NMR instrument (UCB-200). Electrochemical measurements and experiments were made by using either an IBM EC/225 voltametric analyzer potentiostat or a PAR Model 173 potentiostat/galvanostat with a Model 179 digital coulometer insert. A Beckman Model 322 gradient liquid chromatography system with a Model 420 microprocessor controller was used for HPLC analyses. Columns were Bio-Rad Aminex Ion Exclusion HPX-87A Organic Acid Column with a microguard pure column and 0.0025 N  $\text{H}_2\text{SO}_4$  as eluting agent or an Altech Ultrasphere ODS column with a guard column and  $\text{H}_2\text{O-CH}_3\text{CN-CF}_3\text{CO}_2\text{H}$  (40:60:0.1) as eluting agents.

Oxygen analyses were made with a Teledyne Analytical Instruments Class B-2 micro fuel cell. This device uses a lead anode (basic media) and silver-plated cathode and produces current when a gaseous component capable of oxidizing lead is present. An in-house designed and

- (1) Engelsma, G.; Yamamoto, A.; Markham, E.; Calvin, M. *J. Phys. Chem.* **1962**, *66*, 2517–2531.
- (2) Calvin, M. *Acc. Chem. Res.* **1978**, *11*, 369–374.
- (3) Harriman, A.; Porter, G. *J. Chem. Soc., Faraday Trans. 2* **1979**, *75*, 1532–1552.
- (4) Porter, G. *Proc. R. Soc. London, A* **1978**, *362*, 281–303.
- (5) Maliyackel, A. C.; Otvos, J. W.; Spreer, L. O.; Calvin, M. *Proc. Natl. Acad. Sci. U.S.A.* **1986**, *83*, 3572–3574.
- (6) For simplicity and ease of balancing chemical equations the positive charges of the four quaternary *N*-methyl-4-pyridiniumyl groups are not counted in the molecular formulas throughout this paper. They are an integral part of the porphyrin skeleton, and they never enter into any of the chemistry being studied. Thus, for example, the porphyrin ligand itself is considered to have a charge of –2 and the Mn(II) compound would be written  $\text{Mn}^{\text{II}}\text{P}$ .
- (7) (a) Hill, C. L.; Smegal, J. A. *Nouv. J. Chem.* **1982**, *6*, 287–289. (b) Smegal, J. A.; Hill, C. L. *J. Am. Chem. Soc.* **1983**, *105*, 3515–3521. (c) Smegal, J. A.; Schardt, B. C.; Hill, C. L. *J. Am. Chem. Soc.* **1983**, *105*, 3510–3515. (d) Guilmet, E.; Meunier, B. *Tetrahedron Lett.* **1980**, *21*, 4449–4450. (e) Guilmet, E.; Meunier, B. *Nouv. J. Chem.* **1982**, *6*, 511–513. (f) Guilmet, E.; Meunier, B. *J. Mol. Catal.* **1984**, *23*, 115–119.
- (8) Carnieri, N.; Harriman, A.; Porter, G. *J. Chem. Soc., Dalton Trans.* **1982**, 931–938.
- (9) Evans, D. F. *J. Chem. Soc.* **1959**, 2003–2005.

\* To whom correspondence should be addressed at the University of the Pacific.

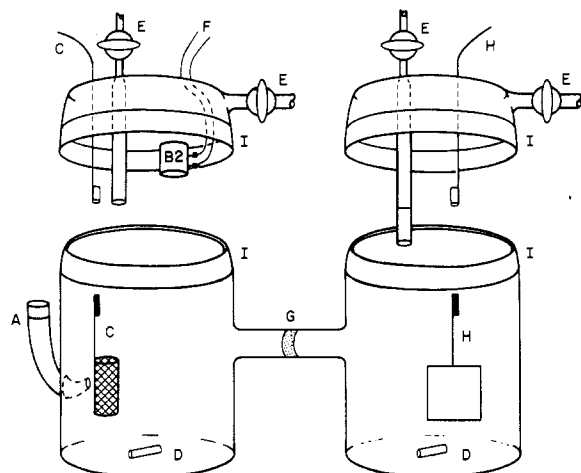

**Figure 1.** Reaction vessel for electrochemical oxidation of  $\text{Mn}^{\text{III}}\text{P}^+$  and  $\text{O}_2$  detection: (A) side tube for SCE reference electrode; (B2) Teledyne micro fuel cell for  $\text{O}_2$  analysis; (C) Pt-mesh working electrode and lead; (D) stir bars; (E) stopcocks for deaeration; (F) leads for micro fuel cell; (G) medium glass frit; (H) Pt-foil counter electrode and lead; (I) ground-glass joints.

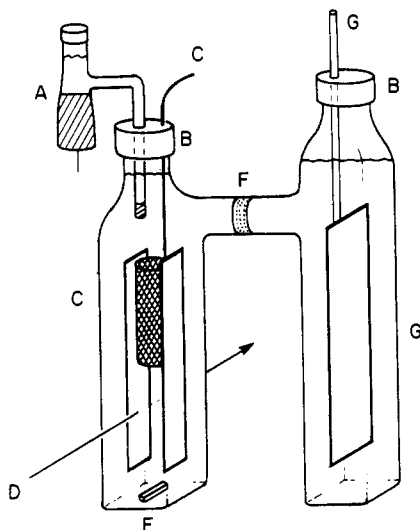
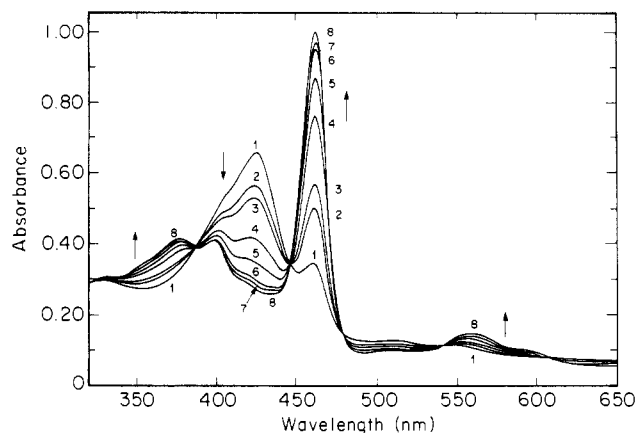

**Figure 2.** Spectroelectrochemical cell: (A) SCE reference electrode; (B) rubber septa; (C) Pt-mesh and -foil working electrode and lead; (D) light path of spectrophotometer; (E) micro stir bar; (F) medium glass frit; (G) Pt-foil counter electrode and lead.

constructed current-to-voltage amplifier was used in conjunction with a recorder to monitor oxygen levels.<sup>10</sup> Since the lead anode is consumed, the micro fuel cell must be periodically calibrated. A typical calibration gave a detection limit of about  $2 \times 10^{-3}$  Torr or 3 ppm of oxygen. Oxygen molecules formed as a result of chemical reactions in aqueous solution must be transferred to the gaseous phase in order to be detected. The transfer rate across the phase boundary and the equilibrium between gaseous and dissolved oxygen must be taken into account in determining oxygen concentrations.

A special electrochemical reaction vessel was constructed for the oxygen experiments (Figure 1). In a typical experiment at pH 10 with an applied potential of 0.9 V (SCE) versus an oxidation potential of 0.8 V for  $\text{Mn}^{\text{III}}\text{P}^+$ , a slight excess of current was passed (1.1 equiv). The current was then shut off, stirring was continued, and the response of the micro fuel cell oxygen analyzer was monitored over a sufficient period of time to allow a large percentage of the high-valent manganese porphyrin to be reduced to  $\text{Mn}^{\text{III}}\text{P}^+$ . Separate experiments established that  $\text{Mn}^{\text{III}}\text{P}^+$  was indeed oxidized by these conditions and that oxygen levels were monitored through at least 2 half-lives of the return of oxidized manganese species to  $\text{Mn}^{\text{III}}\text{P}^+$ .

Spectroelectrochemical studies of the oxidation of  $\text{Mn}^{\text{III}}\text{P}^+$  were performed in a specially constructed cell (Figure 2). Stirring and tem-



**Figure 3.** Visible spectra: (1) spectrum of oxidized  $\text{Mn}^{\text{III}}\text{P}^+$  ( $\lambda_{\text{max}}$  420 nm with 10% remaining  $\text{Mn}^{\text{III}}\text{P}^+$ ); (2) spectrum of  $\text{Mn}^{\text{III}}\text{P}^+$  ( $T = 25^\circ\text{C}$ , 0.1 M sodium phosphate, pH 9.1). Time: (2) 50 min; (3) 100 min; (4) 200 min; (5) 400 min; (6) 800 min; (7) 1600 min; (8) 96 h.

perature control were accomplished by a specially designed cell holder.<sup>11</sup> Kinetic studies of the reduction of the high-valent manganese porphyrin were done either in the same cell after removal of solution from the counter-electrode cell or by replacement of the solution containing oxidized species in a separate spectrophotometric cell. Separate experiments established that dioxygen has no effect on the rate of the reduction of the high-valent manganese porphyrin species.

## Results and Discussion

**Characterization of the Oxidized Manganese Porphyrin.** Oxidation of  $\text{Mn}^{\text{III}}\text{P}^+$  in basic aqueous solution (pH 8) can be accomplished by a number of chemical oxidants such as  $\text{NaOCl}$ ,  $\text{KMnO}_4$ ,  $\text{Na}_2\text{S}_2\text{O}_8$ , and  $\text{H}_2\text{O}_2$ . Electrochemical oxidation can also be used. The same high-valent species with an absorption maximum near 420 nm is produced independently of the means of oxidation.

A novel route to the high-valent species involves reaction of oxygen gas with  $\text{Mn}^{\text{II}}\text{P}$ . Manganese(II) porphyrin species can only be produced in rigorously deoxygenated solutions. In the presence of oxygen the final stable species is a manganese(III) porphyrin. Hoffman, Basolo, and co-workers in a series of papers<sup>12</sup> describe their investigation of an intermediate oxygen-manganese porphyrin adduct species in aprotic solvents at low temperatures, which they conclude is best represented by a manganese(IV) peroxide. However, in alkaline (pH 9) aqueous solution  $\text{Mn}^{\text{II}}\text{P}$  (produced by electrochemical means or by chemical reductants) reacts rapidly with oxygen gas to produce a species having properties identical with those of the high-valent species formed by oxidation of  $\text{Mn}^{\text{III}}\text{P}^+$ .

Careful optical titration with known concentrations of  $\text{NaOCl}$  and coulometric measurements are in agreement with a one-electron oxidation of the original  $\text{Mn}^{\text{III}}\text{P}^+$  species. The oxidation could be metal-centered producing a  $\text{Mn}(\text{IV})$  species or ring-centered to give a  $\text{Mn}(\text{III}) \pi$ -cation-radical species. The optical spectrum (Figure 3) in alkaline solution is very similar to spectra published<sup>13</sup> for well-characterized  $\text{Mn}(\text{IV})$  porphyrinato species in aprotic solvents and inconsistent with spectra characteristic of  $\text{Mn}(\text{III}) \pi$ -cation-radical species.<sup>14</sup> Pulse-radiolytic oxidations of various water-soluble  $\text{Mn}(\text{III})$  porphyrins at pH < 3 give very different spectra whose characteristic features are suggestive of a metalloporphyrin  $\pi$  radical cation.<sup>15</sup> Furthermore, Harriman<sup>16</sup> found that the oxidation potential of  $\text{Mn}(\text{III})$  porphyrins increases

(10) Leone, A.; Otvos, J. W.; Calvin, M. Report LBL 23664; Lawrence Berkeley Laboratory: Berkeley, CA, June 1987.

(11) Casti, T. Ph.D. Thesis, University of California, Berkeley, 1985 (LBL Report 20817).  
 (12) Hoffman, B. M.; Szymanski, T.; Brown, T. G.; Basolo, F. *J. Am. Chem. Soc.* **1978**, *100*, 7253-7259 and references therein.  
 (13) (a) Schardt, B. C.; Hollander, F. J.; Hill, C. L. *J. Chem. Soc., Chem. Commun.* **1981**, 765-66. (b) Schardt, B. C.; Hollander, F. J.; Hill, C. L. *J. Am. Chem. Soc.* **1982**, *104*, 3964-3972.  
 (14) Spreer, L. O.; Maliyackel, A. C.; Holbrook, S.; Otvos, J. W.; Calvin, M. *J. Am. Chem. Soc.* **1986**, *108*, 1949-1953.  
 (15) Morehouse, K. M.; Neta, P. *J. Phys. Chem.* **1984**, *88*, 1575-1579.  
 (16) Harriman, A. *J. Chem. Soc., Dalton Trans.* **1984**, 141-146.

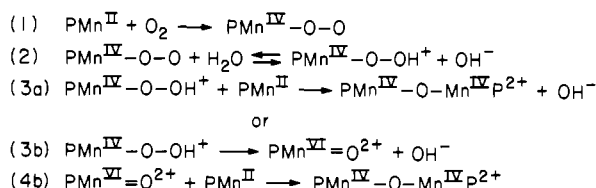
**Scheme I.** Formation of Mn(IV)  $\mu$ -Oxo Dimer from Dioxygen and Mn<sup>II</sup>P

with decreasing pH whereas the potential of the porphyrin ring should be independent of pH. Thus, high pH appears to favor formation of Mn(IV) porphyrins, and low pH favors formation of the Mn(III)  $\pi$  radical cation. At high pH the Mn center is coordinated by hydroxide ion, which stabilizes higher oxidation states. This is consistent with our observation that addition of the strong  $\pi$ -donating ligand  $\text{CH}_3\text{O}^-$  converts a  $\text{Mn}^{\text{III}}\text{TTP}^{2+}$  species to  $\text{Mn}^{\text{IV}}\text{TTP}(\text{OCH}_3)_2$ .<sup>14</sup> (TTP = dianion of tetraphenylporphyrin.)

Various attempts in this laboratory to isolate the manganese(IV) species by lyophilization or precipitation have been unsuccessful. Harriman et al.<sup>17</sup> on the basis of indirect evidence have suggested that  $\text{Mn}^{\text{IV}}\text{P}$  formed at pH 13 exists predominantly in the form of a  $\mu$ -oxo dimer,  $\text{PMn}^{\text{IV}}\text{-O-Mn}^{\text{IV}}\text{P}^{2+}$ . We have evidence from size exclusion chromatography that strongly supports characterization of  $\text{Mn}^{\text{IV}}\text{P}$  at high pH as a dimeric species. A short, 5–8 cm, column of 400-mesh polyacrylamide gel Bio-Gel P-2 (exclusion limit 1800 Da) was hydrolyzed with pH 9.5 borate buffer. An aliquot of a solution containing a 50:50 mol % mixture of  $\text{Mn}^{\text{III}}\text{P}^+$  and the Mn(IV) porphyrin species in the same buffer was placed on the column and eluted with the buffer. On the short column (to minimize contact of the highly oxidizing Mn(IV) species with the polyacrylamide gel) separation into bands was noted. The initial material eluting from the column was highly enriched (10:1) in the Mn(IV) porphyrin, and the last fraction contained pure  $\text{Mn}^{\text{III}}\text{P}^+$ . In control experiments mixtures of known monomeric metalloporphyrins could not be separated, and their elution behavior and retention times were similar to that of  $\text{Mn}^{\text{III}}\text{P}^+$  while the retention time of a Fe(III)  $\mu$ -oxo dimer<sup>18</sup> was similar to that of the Mn(IV) species.

There are two possible formulations for the high-valent dimeric species that are consistent with a one-electron oxidation of the monomeric manganese(III) porphyrins. These are  $\text{PMn}^{\text{IV}}\text{-O-Mn}^{\text{IV}}\text{P}^{2+}$  and  $\text{PMn}^{\text{III}}\text{-O-O-Mn}^{\text{III}}\text{P}$ . The  $\mu$ -oxo Mn(IV) dimer is favored over the Mn(III) peroxo dimer for several reasons. The visible spectrum closely resembles spectra for several well-characterized Mn(IV)  $\mu$ -oxo dimers<sup>19</sup> isolated from aprotic solvents and is quite different from typical  $\text{Mn}^{\text{III}}\text{P}^+$  spectra. The X-ray structure of a species designated as a monomeric peroxo(tetraphenylporphyrinato)manganese(III) complex has recently been described.<sup>20</sup> This species has the peroxo ligand bound in a side-on bidentate fashion and has a visible spectrum with an intense single, sharp Soret band at 437 nm,<sup>21</sup> which actually resembles that of a typical Mn(II) porphyrin.

The reaction of  $\text{Mn}^{\text{II}}\text{P}$  and  $\text{O}_2$  produces a compound identical with that made by oxidation of  $\text{Mn}^{\text{III}}\text{P}^+$ . The oxidation of Fe(II) porphyrins by oxygen has been thoroughly studied.<sup>22</sup> In that case an  $\text{Fe}^{\text{III}}\text{-O}_2\text{-Fe}^{\text{III}}$  peroxo bridge intermediate species has been detected, but the final product is  $\text{Fe}^{\text{III}}\text{-O-Fe}^{\text{III}}$ . The stoichiometry in the manganese(II) porphyrin case is therefore somewhat novel, but plausible sequences can be written to produce a  $\mu$ -oxo Mn(IV) dimer from Mn(II) and  $\text{O}_2$  as well as from Mn(III) and oxidizing agents. In Scheme I the first intermediate species is a manga-

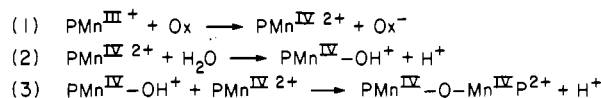
**Scheme II.** Formation of Mn(IV)  $\mu$ -Oxo Dimer from  $\text{Mn}^{\text{III}}\text{P}^+$ 

nese(IV) peroxo complex,  $\text{PMn}^{\text{IV}}(\text{O}_2^{2-})$ , and is similar to that proposed by Hoffman and Basolo<sup>12</sup> for reaction of  $\text{Mn}^{\text{II}}\text{TTP}$  and  $\text{O}_2$  in aprotic solvents. In aqueous systems this species may be protonated. The Mn(IV) peroxo intermediate is at the correct oxidation level to produce the Mn(IV)  $\mu$ -oxo dimer if it reacts with  $\text{Mn}^{\text{II}}\text{P}$ . Alternatively, in a unimolecular sequence the next step might involve loss of  $\text{OH}^-$  to give a manganese(VI) oxo species. Reaction of  $\text{Mn}^{\text{VI}}=\text{O}$  and  $\text{PMn}^{\text{II}}$  then yields the  $\mu$ -oxo Mn(IV) dimer. Scheme II describes the production of  $\text{PMn}^{\text{IV}}\text{-O-Mn}^{\text{IV}}\text{P}^{2+}$  by oxidation of  $\text{PMn}^{\text{III}}\text{P}^+$ .

**Reactions of  $\text{PMn}^{\text{IV}}\text{-O-Mn}^{\text{IV}}\text{P}^{2+}$  in Aqueous Solution.** The high-valent dimer has limited stability in aqueous solutions and reverts to the original  $\text{Mn}^{\text{III}}\text{P}^+$  complex upon standing. The obvious question is the identity of the reducing agent, and speculation has centered on water with oxygen proposed as a possible final product.<sup>4</sup> We first did a number of control experiments involving extensive preelectrolysis of the water–buffer solutions and used different sources and purification schemes for the  $\text{Mn}^{\text{III}}\text{P}^+$  compound. The course of the Mn(IV)  $\mu$ -oxo dimer to  $\text{Mn}^{\text{III}}\text{P}^+$  reaction did not change by these precautions and eliminates extraneous impurities as the reducing agent.

**Water as the Reducing Agent.** A careful examination for oxygen as a product was performed. A trace oxygen analysis utilizing a micro fuel cell was set up (Figure 1).  $\text{Mn}^{\text{III}}\text{P}^+$  was oxidized electrochemically, and oxygen levels were monitored during several half-lives of the return of the Mn(IV) dimer to  $\text{Mn}^{\text{III}}\text{P}^+$ . No evidence for significant oxygen production was found, and control experiments on the sensitivity of the analysis indicated that an upper limit of 5% of the overall  $\text{PMn}^{\text{IV}}\text{-O-Mn}^{\text{IV}}\text{P}^{2+} \rightarrow 2\text{Mn}^{\text{III}}\text{P}^+$  reaction could produce oxygen. These results agree with a recent report<sup>23</sup> using a different analytical method where again no evidence for oxygen production was found. Also, tests<sup>24</sup> for  $\text{H}_2\text{O}_2$  were performed after first removing  $\text{Mn}^{\text{III}}\text{P}^+$  by passage through a cation-exchange column. Again, no evidence for  $\text{H}_2\text{O}_2$  was observed, although control experiments verified adequate sensitivity.

**Loss of Optical Density during Reduction.** Repetitive scans of the visible spectrum as the high-valent dimer reverts to  $\text{Mn}^{\text{III}}\text{P}^+$  show five well-developed isosbestic points (Figure 3). Even with concentrated solutions the isosbestic points below 500 nm are maintained and less than 1% of the total optical density could be due to colored intermediates as the reduction of  $\text{PMn}^{\text{IV}}\text{-O-Mn}^{\text{IV}}\text{P}^{2+}$  to  $\text{Mn}^{\text{III}}\text{P}^+$  occurs. The highest intensity line (Figure 3) is the spectrum taken after 96 h, which is more than 10 half-lives of the reaction under the experimental conditions. This represents 94% of the original intensity, and more protracted waiting did not yield a higher absorbance. Repeated experiments with either chemical oxidants such as  $\text{OCl}^-$  or electrochemical oxidation of  $\text{Mn}^{\text{III}}\text{P}^+$  and with repeated oxidation–return sequences using the same sample gave similar results with a range of 90–94% return to original intensity levels. The rate of the return is dependent on pH with faster rates at low pH. Experiments were done in which  $\text{Mn}^{\text{III}}\text{P}^+$  was oxidized electrochemically at pH 10.5 (NaCl as electrolyte) and the pH was adjusted to 4.0 by addition of HCl. After correction for the small dilution factor, the percentage return still fell in the 90–94% range even though the rate was ca. 100 times faster.

The degradation of the porphyrin chromophore could occur during the oxidation to the  $\text{PMn}^{\text{IV}}\text{-O-Mn}^{\text{IV}}\text{P}^{2+}$  species or could be the result of an unusual disproportionation reaction with each degraded porphyrin ring supplying multiple electrons (9–16) to

(17) Carnieri, N.; Harriman, A.; Porter, G. *J. Chem. Soc., Dalton Trans.* **1982**, 931–938.

(18) Harris, F. L.; Toppen, D. L. *Inorg. Chem.* **1978**, *17*, 71–73.

(19) Groves, J. T.; Kruper, W. J., Jr.; Haushalter, R. C. *J. Am. Chem. Soc.* **1980**, *102*, 6375–6377.

(20) VanAtta, R. B.; Strouse, C. E.; Hanson, L. K.; Valentine, J. S. *J. Am. Chem. Soc.* **1987**, *109*, 1425–1434.

(21) Valentine, J. S.; Quinn, A. E. *Inorg. Chem.* **1976**, *15*, 1997–1999.

(22) Chin, D. H.; LaMar, G. N.; Balch, A. L. *J. Am. Chem. Soc.* **1980**, *102*, 4344–4350.

(23) Harriman, A.; Christensen, P. A.; Porter, G.; Morehouse, K.; Neta, P.; Richoux, M.-C. *J. Chem. Soc., Faraday Trans. 1* **1986**, *82*, 3215–3231.

(24) Feigl, F.; Anger, V. *Spot Tests in Inorganic Analysis*, 6th ed.; Elsevier: New York, 1972; p 78.

reduce the remainder of the oxidized species. The observation that the loss of porphyrin is independent of the chemical oxidant ( $\text{OCl}^-$ ,  $\text{H}_2\text{O}_2$ ,  $\text{Fe}(\text{CN})_6^{3-}$ ) used for  $\text{Mn}^{\text{III}}\text{P}^+$  is an argument against oxidative degradation. In a spectroelectrochemical experiment  $\text{Mn}^{\text{III}}\text{P}^+$  was first oxidized at  $E = 0.9$  V (pH 11.5) to 90% completion (20 min); then the applied potential was lowered to +0.1 V and the  $\text{PMn}^{\text{IV}}\text{O}-\text{Mn}^{\text{IV}}\text{P}^{2+}$  was electrochemically reduced (15 min). Isobestic points were obtained during both the oxidation and reduction steps, but greater than 98% of the original  $\text{Mn}^{\text{III}}\text{P}^+$  optical densities were observed. This confirms that loss of chromophore occurs as the  $\text{Mn}^{\text{IV}}\text{P}$  dimer returns to the  $\text{Mn}^{\text{III}}\text{P}^+$  monomer in aqueous solution in the absence of added reductants.

**Reaction with Olefins.** Further evidence against oxidative degradation was supplied by experiments involving addition of an oxidizable substrate. There are numerous reports<sup>7</sup> in the literature of manganese porphyrins catalyzing the epoxidation of olefins and hence serving as synthetic model systems for cytochrome P-450. These studies involve reaction in aprotic solvents, with no analogous observation reported for water-soluble manganese porphyrins. In our experiments  $\text{Mn}^{\text{III}}\text{P}^+$  was first oxidized electrochemically and then a 100-fold or greater excess of 3-buten-1-ol or maleic acid was added (at the same buffered pH 9.1 as the manganese porphyrin). The reduction to the original  $\text{Mn}^{\text{III}}\text{P}^+$  complex was greatly accelerated and 99–100% of the original optical density was achieved. The result establishes that the porphyrin macrocycle is degraded during the reduction of the  $\text{Mn}(\text{IV})$  dimeric species to  $\text{Mn}(\text{III})$  and provides suggestions regarding the mechanism of the disproportionation reaction.

**HPLC Chromatography.** Further confirmation of the unusual disproportionation process was provided by HPLC analysis before and after the return of the  $\text{Mn}(\text{IV})$   $\mu$ -oxo dimer to  $\text{Mn}^{\text{III}}\text{P}^+$ . An aliquot of a freshly prepared solution of  $\text{Mn}^{\text{III}}\text{P}^+$  in either phosphate or borate buffer was injected into an HPLC column. With an organic acid column all positive ions were trapped in a guard column, and the chromatogram of the original mixture showed only a peak for the buffer components. Another injection was made immediately after electrochemical oxidation; this chromatogram exhibited no new peaks. Then a series of injections was made during the time that the high-valent dimer to  $\text{Mn}(\text{III})$  monomer reaction was occurring. Several new peaks appeared that increased in size as the reaction proceeded. Since no organic matter other than the porphyrin was originally present, this implies that a disproportionation occurs involving multiple-electron oxidation of a small percentage of the porphyrin macrocycles and a single-electron reduction of  $\text{Mn}(\text{IV})$  to  $\text{Mn}(\text{III})$ .

One neutral organic product of the porphyrin oxidation was identified as maleimide by coelution experiments. Many of the expected products of extensive oxidation of a tetrakis(*N*-methyl-4-pyridiniumyl)porphyrin macrocycle in aqueous solution would carry a positive charge due to the *N*-methylpyridinium moiety. These products would be trapped in the cation-exchange guard column used with the organic acid column to prevent the manganese porphyrin from contaminating the column. Comparable experiments with an ODS column and gradient  $\text{H}_2\text{O}-\text{C}-\text{H}_3\text{CN}$  elution revealed a number of other peaks due to oxidative degradation of the porphyrin, but these were poorly resolved. Attempts at building up a larger concentration of organic products by sequential electrochemical oxidations of the same sample were complicated by the observation that the chromatogram pattern was altered after the second oxidation step. This indicates that at least some of the disproportionation products were susceptible to subsequent oxidation. This complication was even more pronounced when chemical oxidants such as  $\text{OCl}^-$  were used. However, identification of maleimide as a product is adequate confirmation of the main features of the disproportionation reaction.

**Kinetics of Reduction Reaction.** As might be expected, the kinetics of the multi-electron disproportionation reaction are complicated. The rate is pH dependent, with faster rates at lower pH. Simple first-order or second-order plots of the decrease in absorbance at 424 nm (disappearance of dimer) or of the increase in absorbance at 462 nm (appearance of monomer) do not give

straight lines over the entire course of the reaction (pH buffered with 0.1 M sodium phosphate). For  $8 < \text{pH} < 12$ , plots of  $\ln [(A_t - A_\infty)/(A_0 - A_\infty)]$  are reasonably straight over the last 30% of the reaction, but the plots show curvature to slower rates in the initial stages.

**Mechanism.** A mechanism for the multiple-electron disproportionation reaction must be consistent with two important observations: (1) there is no detectable buildup of colored intermediates and (2) the rate increases as pH decreases. Our observation that the  $\text{Mn}(\text{IV})$   $\mu$ -oxo dimer species reacts fairly rapidly with water-soluble olefinic compounds offers a possible explanation for the first point, that is, observation of good isobestic points throughout the course of the reaction. If the rate-determining step involves the initial oxidation of a specific porphyrin, then the molecule would lose a significant amount of resonance stabilization. The product of the initial oxidation, either isoporphyrin or opened bilirubin type molecule, would be able to undergo facile, successive oxidations with remaining  $\text{Mn}(\text{IV})$   $\mu$ -oxo dimer acting as the oxidizing agent. This is reasonable since our experiments with water-soluble olefins establish the fact that the  $\text{Mn}(\text{IV})$   $\mu$ -oxo dimer is capable of oxidizing olefins.

The initial degradation of the porphyrin would produce highly colored species, but as long as subsequent reactions with remaining  $\text{Mn}(\text{IV})$  dimer are fast compared to the first step, no detectable colored intermediates will appear. The observed isobestic points will not occur at the wavelength where the molar absorptivity coefficients of the dimer,  $\epsilon_D$ , and monomeric product,  $\epsilon_M$ , are related by  $\epsilon_D = 2\epsilon_M$ , as is the usual case, but rather where  $\epsilon_D = \alpha(2\epsilon_M)$  and  $\alpha$  is the fraction of the total return of the chromophore (0.90–0.96).

The ultimate organic products must be small segments of the original P macrocycle, and the observation of maleimide as one of these species fits this scheme. Other products might be acids, ketones, aldehydes, or alcohols derived from pyrrole or the *N*-methylpyridinium moiety.

The initial oxidation on a specific porphyrin would be the rate-determining step by the above argument. A recent report<sup>23</sup> on the stability of manganese porphyrins in aqueous solution offers an alternative suggestion that hydrogen peroxide is first produced, which then bleaches the porphyrin. We find that detectable quantities of hydrogen peroxide are not present at the end of the reaction. We observe that excess hydrogen peroxide in the presence of the  $\text{Mn}(\text{IV})$   $\mu$ -oxo dimer causes loss of absorbance in the Soret region, but there is also significant buildup of species with absorbance in the 650–750-nm region. There was no observable increase in absorbance at these longer wavelengths as the  $\text{Mn}(\text{IV})$  dimer underwent reduction, even in experiments where high concentrations of manganese porphyrin were used. Also, hydrogen peroxide smoothly oxidizes  $\text{Mn}^{\text{III}}\text{P}^+$  to the  $\text{Mn}(\text{IV})$   $\mu$ -oxo dimer when equivalent amounts are mixed. This argues against a mechanism involving a first step that produces  $\text{H}_2\text{O}_2$  and  $\text{Mn}^{\text{III}}\text{P}^+$ .

A mechanistic scheme for the multiple-electron disproportionation of the  $\text{Mn}(\text{IV})$   $\mu$ -oxo dimer should incorporate an explanation for the pH dependence of the rate. One explanation might be that higher hydrogen ion concentrations favor breakup of the  $\text{Mn}(\text{IV})$   $\mu$ -oxo dimer to more reactive monomer units. The equilibrium between  $\mu$ -oxo dimer and monomer in iron systems has been well studied, and monomers are favored at low pH. In addition, mechanistic studies of the epoxidation of olefins catalyzed by manganese porphyrin invoke  $\text{Mn}(\text{V})$  oxo species as the oxygen-transfer agent. In the present case, a reaction such as  $\text{PMn}^{\text{IV}}\text{O}-\text{Mn}^{\text{IV}}\text{P}^{2+} \rightarrow \text{Mn}^{\text{III}}\text{P}^+ + \text{PMn}^{\text{V}}\text{O}^+$  that is pH dependent may be operative.

Another possible explanation for the pH dependence concerns internal electron transfer within the dimer that is affected by the axial ligands on the manganese. As noted previously, at high pH the manganese ion is coordinated by hydroxide ion, which stabilizes the  $\text{Mn}(\text{IV})$  oxidation level. A possible rate-determining step in the disproportionation of the  $\text{Mn}(\text{IV})$   $\mu$ -oxo dimer involves a rearrangement from a symmetrical charge distribution  $\text{PMn}^{\text{IV}}\text{O}-\text{Mn}^{\text{IV}}\text{P}^{2+}$  to one where oxidation is centered on a porphyrin

ring:  $\text{PMn}^{\text{IV}}\text{-O-Mn}^{\text{III}}\text{P}^{2+}$  (porphyrin  $\pi$  cation radical) or  $\text{P-Mn}^{\text{III}}\text{-O-Mn}^{\text{III}}\text{P}$  (porphyrin dication). These species with ring-centered oxidation would be susceptible to nucleophilic attack by water or hydroxide. Thus, the initial product would be an epoxide or a hydroxy species that would rapidly undergo further oxidation by remaining  $\text{Mn}(\text{IV})$  dimers. As the pH is lowered, water instead of  $\text{OH}^-$  becomes the predominant axial ligand for Mn. This would favor rearrangement within the  $\text{Mn}(\text{IV})$  dimer to species with  $\text{Mn}(\text{III})$  and porphyrin-centered oxidation.

**Acknowledgment.** This work was supported by the Office of Energy Research, Office of Basic Energy Sciences, Chemical Sciences Division of the U.S. Department of Energy, under Contract No. DE-AC03-76SF00098. L.O.S. acknowledges the support of Associated Western Universities by a Summer Faculty Participation Award.

**Registry No.**  $\text{Mn}^{\text{III}}\text{P}^+$ , 70649-54-6;  $\text{PMn}^{\text{IV}}\text{-O-Mn}^{\text{IV}}\text{P}^{2+}$ , 114595-73-2;  $\text{Mn}^{\text{II}}\text{P}$ , 72924-08-4;  $\text{O}_2$ , 7782-44-7; 3-buten-1-ol, 627-27-0; maleic acid, 110-16-7; maleimide, 541-59-3.

Contribution from the Department of Chemistry, University of Florence, via Gino Capponi 7, 50121 Florence, Italy, Faculty of Pharmaceutical Sciences, Nagoya City University, Nagoya, Japan, and Institute of Agricultural Chemistry, University of Bologna, Bologna, Italy

## Kinetic Studies on Metal Removal from Transferrins by Pyrophosphate. Investigation on Iron(III) and Manganese(III) Derivatives

Ivano Bertini,<sup>\*,†</sup> Junzo Hirose,<sup>‡</sup> Claudio Luchinat,<sup>§</sup> Luigi Messori,<sup>†</sup> Mario Piccioli,<sup>†</sup> and Andrea Scozzafava<sup>†</sup>

Received March 27, 1987

The kinetics of metal removal from iron(III) transferrin by pyrophosphate (PP) has been studied at pH 7.4. A biphasic behavior is observed that is related to the presence of two metal sites. The dependence of the  $k_1$  and  $k_2$  values on PP concentration provides evidence of the existence of more than one pathway for the metal release reaction in both sites. The effect of chaotropic agents on the kinetic parameters has been studied. All the data are interpreted and rationalized on the grounds of a kinetic model that represents an extended version of the Bates mechanism. Kinetic data on manganese(III) transferrin are also shown.

### Introduction

We have been recently studying the kinetics of release of metal ions from metallotransferrins in the presence of increasing amounts of pyrophosphate. The iron(III)-transferrin-carbonate derivative is the most representative compound of this class on account of its biological significance.<sup>1,2</sup> We had designed an experiment to measure the kinetics of release of iron under different solution conditions by using desferrioxamine B as a sink to ensure the complete removal of the metal.<sup>3</sup> The kinetics was followed through the decrease in intensity of the tyrosinate-to-metal charge-transfer bands. Such a decay was fit by an equation of the type

$$A_t = (A_0 - A_\infty)(0.5e^{-k_1t} + 0.5e^{-k_2t}) + A_\infty \quad (1)$$

where  $A_t$  and  $A_0$  are the absorbances, at the observation wavelength, at  $t$  and zero times, respectively,  $A_\infty$  is the absorbance at infinite time, and  $k_1$  and  $k_2$  are the first-order kinetic parameters for the two transferrin sites. This equation assumes that the two metal sites are completely independent from each other. This point has been addressed by several authors<sup>4-7</sup> and is proved a posteriori<sup>6,7</sup> to represent a reasonable assumption. The two kinetic constants for the two sites have been determined under various concentrations of nonsynergistic anions. We have used pyrophosphate (PP hereafter) as a scavenger anion—i.e. as an anion that increases the rate of release of the metal ion although its binding affinity for iron is weaker than that of transferrin itself—on the grounds of early experiments that demonstrated its efficiency in facilitating iron removal;<sup>8-12</sup> we have investigated also the effect of the chaotropic agent perchlorate on the kinetics of release. After this research program was well ahead, a paper by Harris et al. appeared<sup>13</sup> which shows that accurate measurements of the initial iron release rate in a large range of phosphonate concentrations reveal a previously unobserved profile of the average rate constant for release versus the pyrophosphate ligand concentration. The experimental data are rationalized on the grounds

of a complex kinetic model consisting of both a saturation and a linear term; the former dominates at low scavenger concentration whereas the latter is prevalent at high scavenger concentration. This finding contradicts previous hypotheses and draws new interest to such a controversial topic. Indeed, despite the fact that in the last decade many reports have appeared in the literature on the reaction of iron removal from transferrin,<sup>2</sup> serious limitations to a general interpretation of the many reported results come from the extreme variability of the experimental conditions under which the kinetic experiments have been run as well as of the used data treatments.

In light of the latest developments, we report here the analysis of our experimental data, recorded under homogeneous conditions, in terms of two kinetic constants and their dependence on various solution conditions. Our study is a further attempt to rationalize the matter and to evaluate the specific relevance of the various factors on the overall process. In particular, we have studied the effect of both a representative scavenger agent (PP) and a representative chaotropic agent (perchlorate) on the kinetics of metal release and focused on their mutual interactions.

The data on the manganese(III)-transferrin-carbonate system are also discussed.

### Experimental Part

Human serum transferrin (Tf hereafter) in the apo form was pur-

- (1) Aisen, P.; Listowsky, I. *Annu. Rev. Biochem.* **1980**, *49*, 357.
- (2) Chasteen, N. D. *Adv. Inorg. Biochem.* **1983**, *5*, 201.
- (3) Pollack, S.; Aisen, P.; Lasky, F. D.; Vanderhoff, G. *Br. J. Haematol.* **1976**, *34*, 231.
- (4) Kretchmar, S. A.; Raymond, K. N. *J. Am. Chem. Soc.* **1986**, *108*, 6212.
- (5) Baldwin, D. A. *Biochim. Biophys. Acta* **1980**, *623*, 183.
- (6) Harris, W. R. *J. Inorg. Biochem.* **1984**, *21*, 263.
- (7) Bertini, I.; Hirose, J.; Kozlowsky, H.; Luchinat, C.; Messori, L.; Scozzafava, A. *Inorg. Chem.* **1988**, *27*, 1081.
- (8) Egedy, A. *Biochim. Biophys. Acta* **1975**, *411*, 349.
- (9) Pollack, S.; Vanderhoff, G.; Lasky, F. D. *Biochim. Biophys. Acta* **1977**, *497*, 481.
- (10) Kojima, N.; Bates, G. W. *J. Biol. Chem.* **1979**, *254*, 8847.
- (11) Cowart, R. E.; Swope, S.; Loh, T. T.; Chasteen, N. D.; Bates, G. W. *J. Biol. Chem.* **1986**, *261*, 4607.
- (12) Morgan, E. H. *Biochim. Biophys. Acta* **1979**, *580*, 312.
- (13) Harris, W. R.; Rezvani, A. B.; Bali, P. K. *Inorg. Chem.* **1987**, *26*, 2711.

<sup>†</sup> University of Florence.

<sup>‡</sup> Nagoya City University.

<sup>§</sup> University of Bologna.